



Unique

Porcelain tiles

Unique_19,5 * 121,5 T.Oxik

Unique

Porcelain tiles



UNIQUE

UNIQUE



19,5 * 121,5 * 1 cm | 8 * 48"

RECTIFIED	NATURAL
	BN2
UNIQUE	25645



15 * 90 * 1 cm | 6 * 36"

RECTIFIED	NATURAL
	BN27
UNIQUE	25646

T.BARCELOS

19,5 * 19,5 cm | 8 * 8"

RECTIFIED	NATURAL
	P23
T. BARCELOS	25371



T. BARCELOS

T.OXIK





19,5 * 19,5 cm | 8 * 8"

RECTIFIED	NATURAL
	P23
T. OXIK	25372

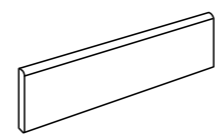
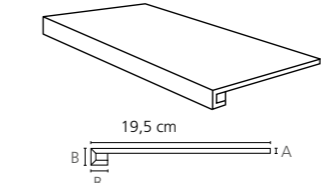
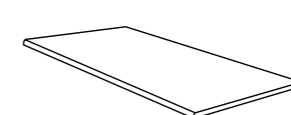

T. OXIK

PIEZA COMPLEMENTARIA | COMPLEMENTARY PIECE

Rodapie - Skirting	Peldaño técnico - Technical stair - thread	Peldaño romo - Rounded stair - thread	*S.K.I.	*S.K.D.	*Z.R.I.	*Z.R.D.
						
8 * 61 cm 3 * 24" P35	19,5 * 121,5 cm 8 * 48" P75 A= 1 cm B= 3 cm	19,5 * 121,5 cm 8 * 48" P77	8 * 30 cm 3 * 12" P51			

CARACTERÍSTICAS TÉCNICAS | TECHNICAL CHARACTERISTICS

joint	frost proof	versatile	mat/gloss	diferent shades	shade variation	various graphics	various moulds
							

CARACTERÍSTICAS TÉCNICAS ANTIDESLIZAMIENTO | ANTI-SLIP CHARACTERISTICS

Ensayo Essay	Características Features	Resultado Result
DIN 51130	Ángulo crítico (Pies calzados) Critical angle (footwear)	R9
UNE-ENV 12633	Antideslizamiento (Test del péndulo) Slip resistance (Pendulum test)	Class 1

EMBALAJE | PACKING

Formato Sizes	Cajas Boxes			Pallet			Cont./20' 21500 kg.	Cont./20' 24000 kg.	
	Piezas	m ² / sq.m	kg	Cajas	m ² / sq.m	kg			
cm									
15 * 90 * 1	7	0,95	21,70	48	45,60	1066	100 * 100 * 75	919,70	1026,64
19,5 * 121,5 * 1	4	0,95	22,17	40	38	912	128 * 95 * 55	895,83	1000
inch	Units	ft ²	lb	Boxes	ft ²	lb	Sizes inch approx.	ft ²	ft ²
5 7/8 * 35 7/16 * 3/8	7	10,23	47,84	48	490,84	2350,53	39 3/8 * 39 3/8 * 29 1/2	9899,65	11050,77
7 11/16 * 47 13/16 * 3/8	4	10,23	48,88	40	409,03	2010,96	50 3/8 * 37 3/8 * 21 5/8	9642,75	10764

(Los pesos aquí reflejados pueden sufrir ligeras variaciones en función del lote de producción. Weights shown here may slightly vary depending on the production lot.)