



141

142

Satya

Porcelain tiles

Satya-H_60*120 Satya-H_60*60



Satya-G_60*60 Satya-G_60*120
 R. Satya-G_60 R.P. Satya-G_60 P.V. Satya-G
 ANG. P.V. Satya-G E.P.V. Satya-G REJ. Satya-G
 ANG. REJ. Satya-G

Satya

Porcelain tiles

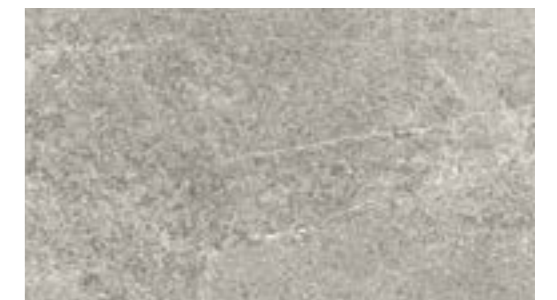
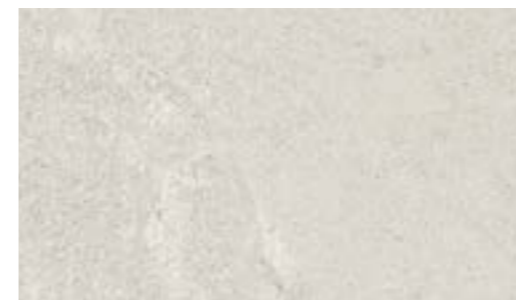
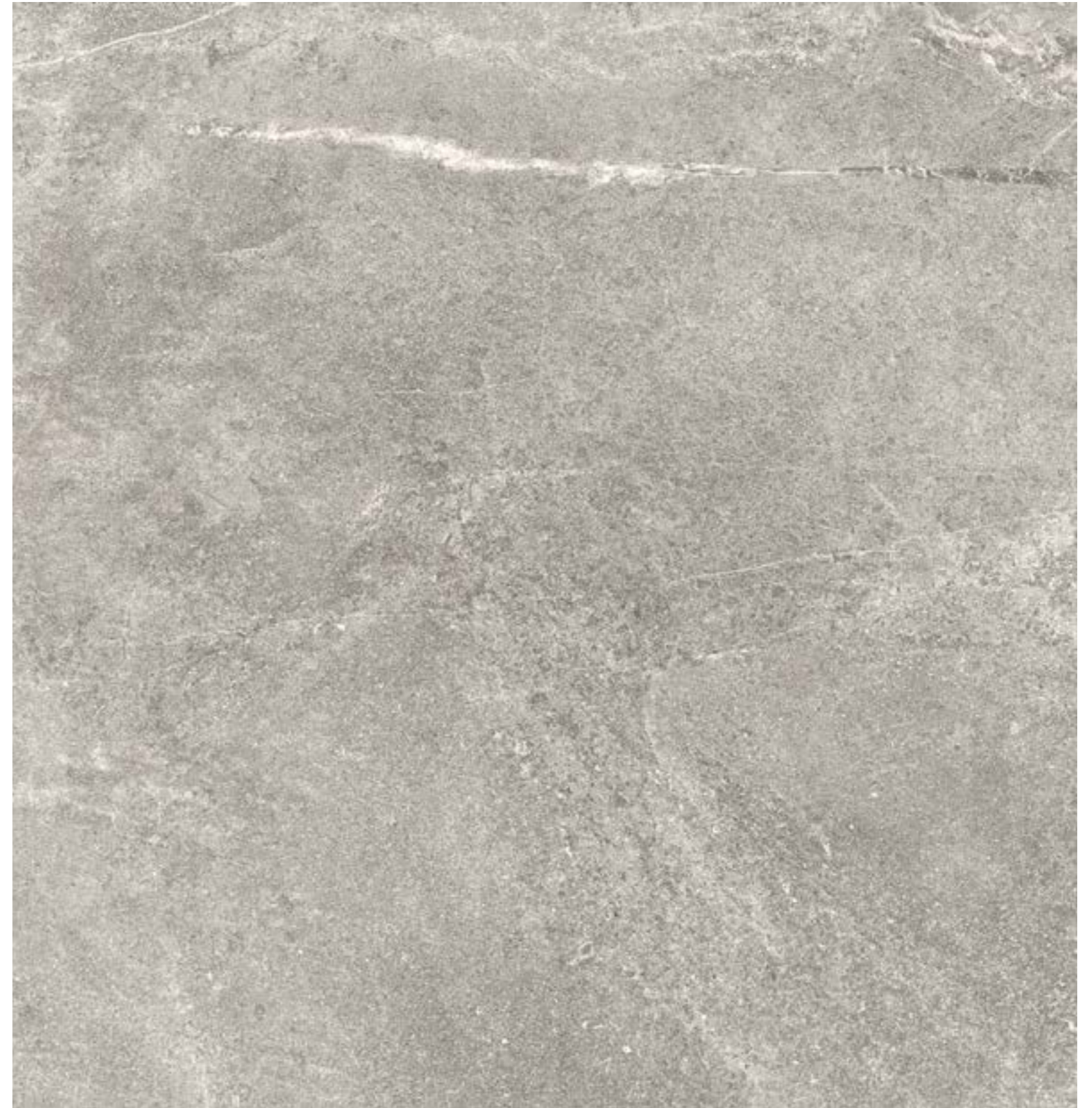

SATYA-B

SATYA-H

SATYA-G



SATYA

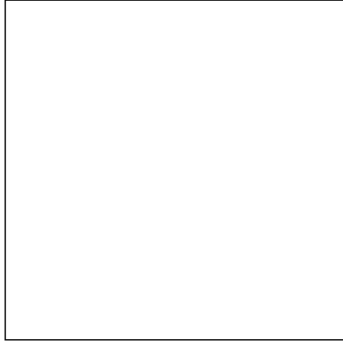

15 patterns

90 * 90 * 1 cm | 36 * 36"

RECTIFIED	NATURAL	ANTISLIP
	BN48	BN90
B	25442	25445
H	25444	25447
G	25443	25446

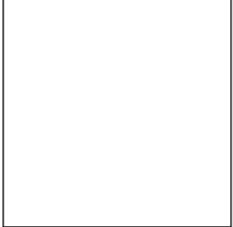

24 patterns

60 * 60 * 1 cm | 24 * 24"

RECTIFIED	NATURAL	ANTISLIP
	BN33	BN88
B	25436	25439
H	25438	25441
G	25437	25440



18 patterns

60 * 120 * 1 cm | 24 * 48"

RECTIFIED	NATURAL
	BN72
B	25432
H	25434
G	25433

D. SATYER

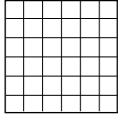

30 * 30 cm | 12 * 12"

NO RECTIFIED	NATURAL
	P45
B	21424
H	21415
G	21416

D. VERITAS

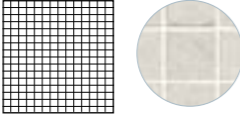

30 * 30 cm | 12 * 12"

NO RECTIFIED	NATURAL
	P58
B	21456
H	21336
G	21337

D. SATY



29 * 29 cm | 12 * 12"

NO RECTIFIED	NATURAL
	P55
B	21673
H	21675
G	21674

 **26200** ALUMINIO/90/MAT _ 90 * 0,5 cm | 35 * 0,2" _ **P39**





 **26201** L. GOLDEN/MAT/90 _ 90 * 0,5 cm | 35 * 0,2" _ **P39**

EMBALAJE | PACKING

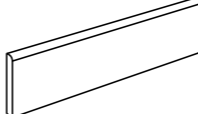
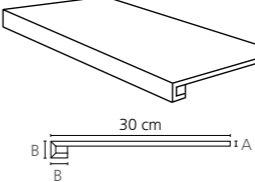
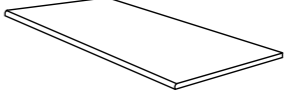

Formato Sizes	Cajas Boxes			Pallet			Cont./20'	Cont./20'
	Piezas	m ² /sq.m	kg	Cajas	m ² /sq.m	kg	21500 kg.	24000 kg.
cm							Tamaño cm aprox.	
60 * 120 * 1	2	1,44	33,18	27	38,88	920	120 * 80 * 75	908,61 1014,26
60 * 60 * 1	3	1,08	24,30	36	38,88	899	120 * 80 * 75	929,83 1037,95
90 * 90 * 1	2	1,62	37,96	22	35,64	860	105 * 95 * 75	891 994,60
inch							Sizes inch approx.	
23 5/8 * 47 1/4 * 3/8	2	15,50	73,16	27	418,50	2028,60	41 5/16 * 31 1/2 * 29 1/2	9780,26 10917,50
23 5/8 * 23 5/8 * 3/8	3	11,63	53,59	36	418,50	1982,30	41 5/16 * 31 1/2 * 29 1/2	10008,72 11172,53
35 7/16 * 35 7/16 * 3/8	2	17,44	83,70	22	383,63	1896,30	41 5/16 * 37 3/8 * 29 1/2	9590,72 10705,92

(Los pesos aquí reflejados pueden sufrir ligeras variaciones en función del lote de producción. Weights shown here may slightly vary depending on the production lot.)

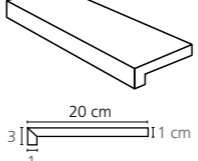
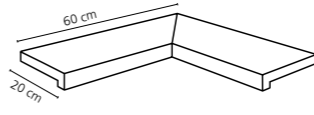
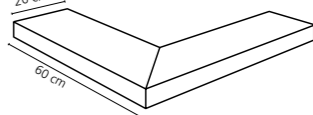
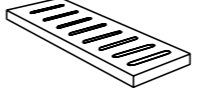
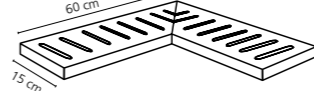

PIEZA COMPLEMENTARIA | COMPLEMENTARY PIECE

Rodapie - Skirting	Peldaño técnico - Technical stair - thread	Peldaño romo - Rounded stair - thread	*S.K.I.	*S.K.D.	*Z.R.I.	*Z.R.D.
						
8 * 90 cm 3 * 36" P44 8 * 60 cm 3 * 24" P34	30 * 90 cm 12 * 36" P76 30 * 60 cm 12 * 24" P54 30 * 120 cm 12 * 48" P75 A= 1 cm B= 3 cm	30 * 90 cm 12 * 36" P61 30 * 60 cm 12 * 24" P64 30 * 120 cm 12 * 48" P77	8 * 30 cm 3 * 12" P55			

PIEZA ESPECIAL PISCINA | SPECIAL PIECE POOL

Peldaño Vierteagua Pool Coping	Peldaño vierteagua angulo Pool Coping internal corner	Peldaño vierteagua esquina Pool Coping external corner
		
20 * 60 cm 8 * 24" P61	20 * 60 cm 8 * 24" P70 (PACK 2 units)	20 * 60 cm 8 * 24" P70 (PACK 2 units)
Rejilla Drainage grate	Angulo rejilla Angle corner drainage grate	Taco rejilla Square corner drainage grate
		
15 * 60 * 2,2 cm 6 * 24" P54	15 * 60 * 2,2 cm 6 * 24" P75 (PACK 2 units)	15 * 15 * 2,2 cm 6 * 6" P85

CARACTERÍSTICAS TÉCNICAS | TECHNICAL CHARACTERISTICS

joint	frost proof	versatile	matt	shade variation	various graphics	diferent shades
						

CARACTERÍSTICAS TÉCNICAS ANTIDESLIZAMIENTO | ANTI-SLIP CHARACTERISTICS

Ensayo Essay	Características Features	Resultado Result	
		NATURAL	ANTISLIP
DIN 51130	Ángulo crítico (Pies calzados) Critical angle (footwear)	R9	R11
DIN 51097	Ángulo crítico (Pies descalzos) Critical angle (Wet loaded barefoot)	A+B	A+B+C
BS 7976-2	Antideslizamiento (Test del péndulo) Slip resistance (Pendulum test-PTV)	+36 Wet	+36 Wet
UNE-ENV 12633	Antideslizamiento (Test del péndulo) Slip resistance (Pendulum test)	Class 1	Class 3
ANSI A137.1	Coefficiente de Fricción Dinámico Dynamic Coefficient of Friction (DCOF)	-	> 0,42
ISO 10545-7	Resistencia a la Abrasión Superficial Resistance to Surface Abrasion	PEI 4	
	Producto certificado por CSTB CSTB Certified product	✓	✓